



 **CARGO RACK**
STORAGE SOLUTIONS FOR MILITARY CARGO RACK

 **BANAIR**



CARGO RACK

STORAGE SOLUTIONS FOR MILITARY CARGO AND BULK

- › 463L / ISU90
- › TRICON
- › QUADCON
- › BICON
- › MOBILE SOLUTIONS
- › ALL TYPES OF BULK CARGO
(e.g crates, pallets & other oversized items)



HIGH-DENSITY RACK
BANAIR systems compatibility



INTEGRATED ROOF
Optional roof systems engineered to take snow / wind loads for challenging environments



SPACE SAVING
The original and best way to optimize your available warehouse cube: eliminate stored air. BANAIR.



REPAIRABLE
Impact damage, dents & scrapes can all be repaired on 100% of BANAIR equipment, protecting your workforce & long-term



DURABLE
Designed tough for demanding workplace environments. Built to last. Lifetime Warranty.



MOBILE OPTIONS
All BANAIR systems are designed to adapt to suit your changing mission.

PROBLEM

- ❌ **Poor space utilization - No vertical storage**
- ❌ **Labor intensive** handling
- ❌ **Exposed** Containers / Crates = **materials damaged** by weather & the environment
- ❌ **Poor readiness = Poor deployment capability**
- ❌ **Drain** on warehouse potential
- ❌ **Limited expansion** potential for increased operations



SOLUTION



CARGO



TRICON



UNIVERSAL RACK



LAY-DOWN



PUSH-BACK

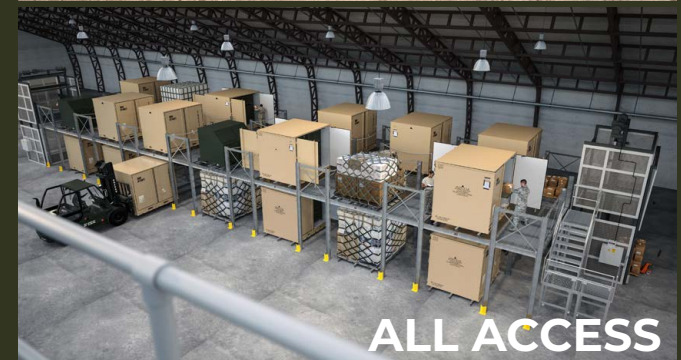

ALL ACCESS



463L

ISU90

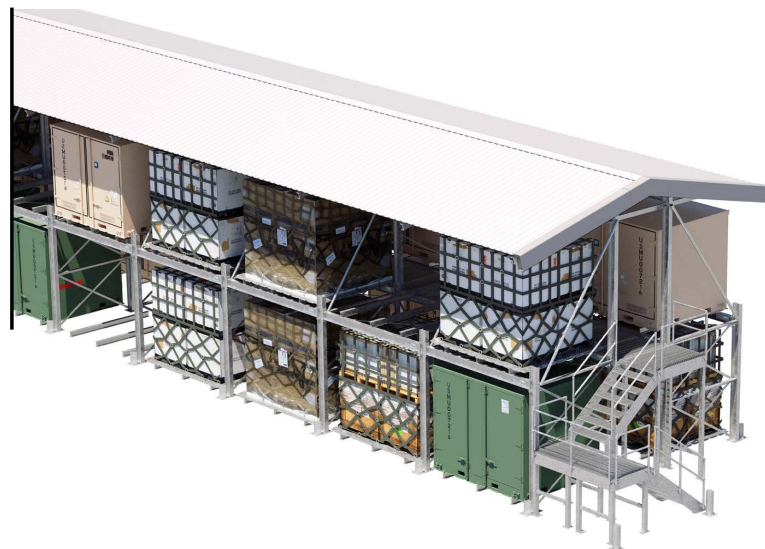
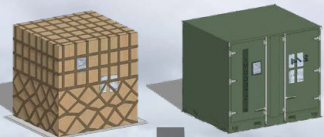

CARGO

MILITARY CARGO RACK

Flexible Storage Solutions For Cargo



OPTIONAL ROOF



SPACE SAVING



MOBILE



READINESS



DURABLE



FORKLIFT

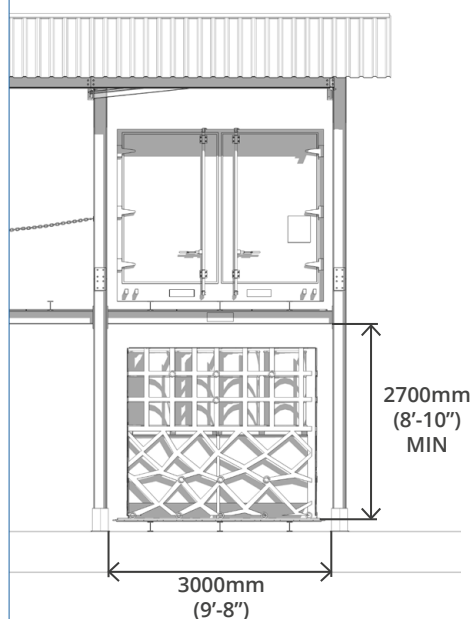
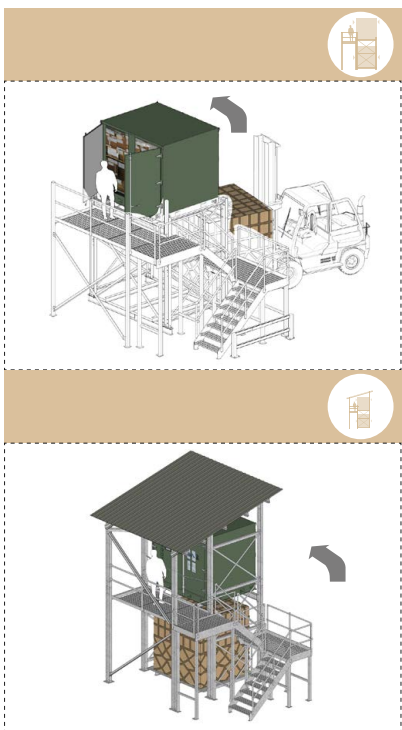

Roof systems engineered to take snow / wind loads for challenging environments

Central inspection catwalk

Single or double row access



Ground level fork entry bars

Stairkits



BULK STORAGE



BACK-TO-BACK WITH CENTRAL WALKWAY

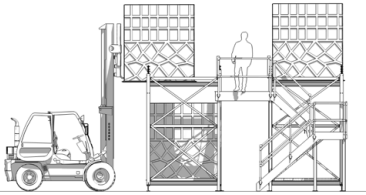

LAYDOWN

MILITARY CARGO RACK

Flexible Storage Solutions For Cargo

STACKABLE



CLASS IV



INTEGRATED ROOF



DURABLE



FORKLIFT



INTEGRATED ROOF

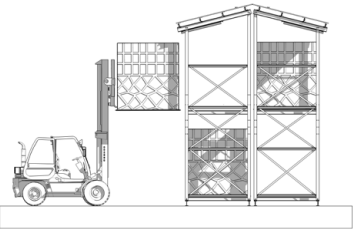

CENTRAL INSPECTION WALKWAY WITH INTEGRATED ROOF

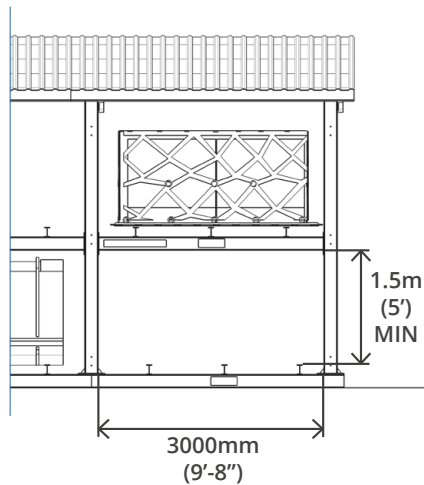
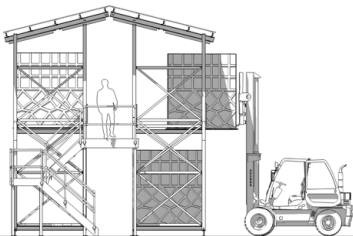

LAYDOWN CARGO RACK is designed for the strategic & efficient storage of smaller height loads e.g for crates, tire stillages, razor wire rolls, pickets, sandbags (x4 US Govt. wooden pallets per 463L)

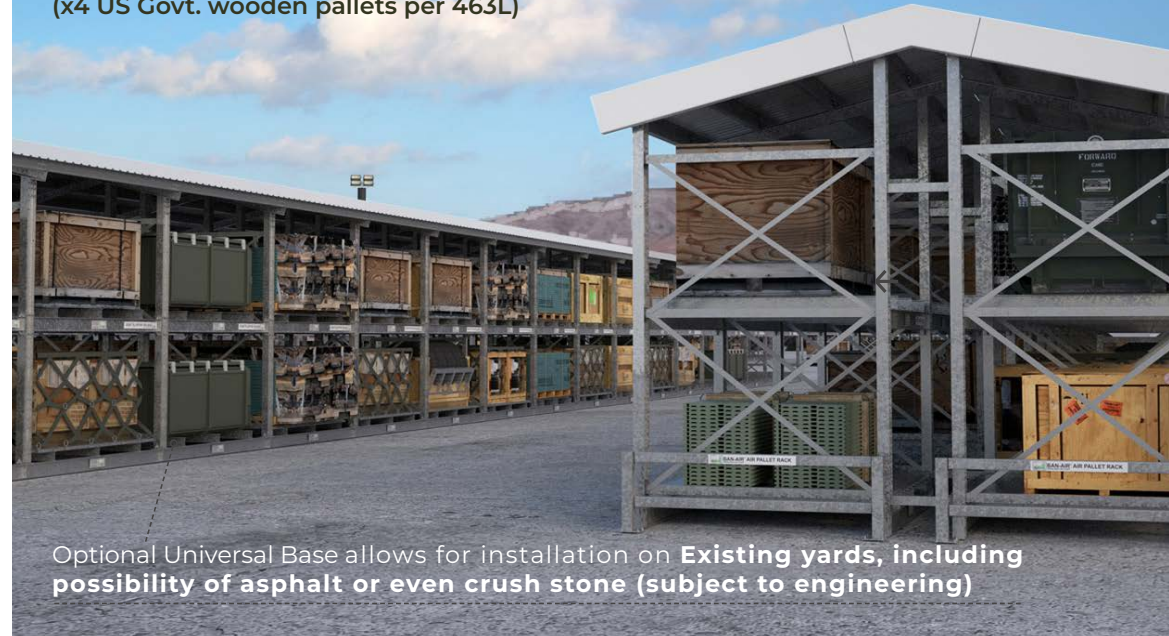

Optional Universal Base allows for installation on **Existing yards, including possibility of asphalt or even crush stone (subject to engineering)**





TOP VIEW

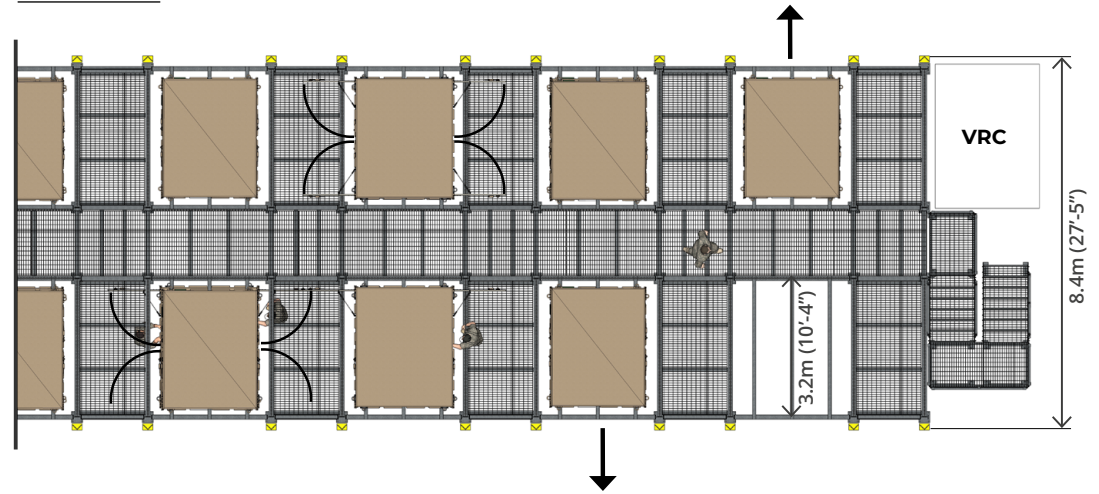

ALL ACCESS

MILITARY CARGO RACK
Flexible Storage Solutions For Cargo

STACKABLE



ALL ACCESS



READINESS



DURABLE



FORKLIFT



END VIEW

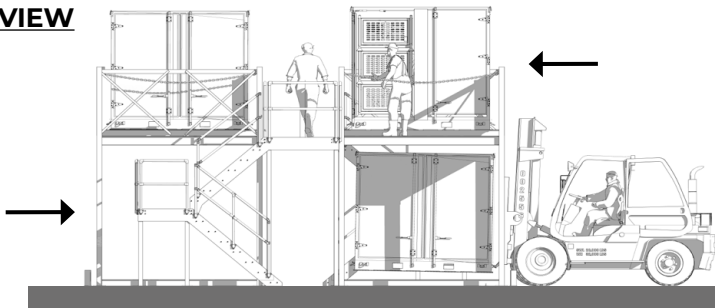

FRONT VIEW

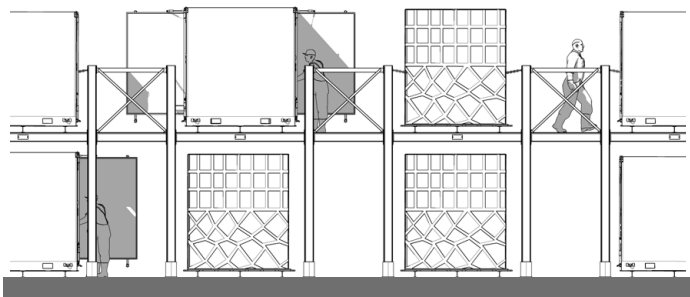



MOBILE CARRIAGES

Our **TRICON** rack can be installed on **MOBILE CARRIAGES** to allow for **DENSE STORAGE** within the same footprint.



TRICON

MILITARY CARGO RACK
Flexible Storage Solutions For Cargo



STACKABLE



SPACE SAVING



MOBILE



READINESS



DURABLE



FORKLIFT



TRICONS rest on each level of storage on **custom steel lugs** which engage by design with the container's four corner castings. This provides **horizontal stability** to every TRICON in storage, improving **safety** through design in case of rack impacts, and facilitating mobile rack applications

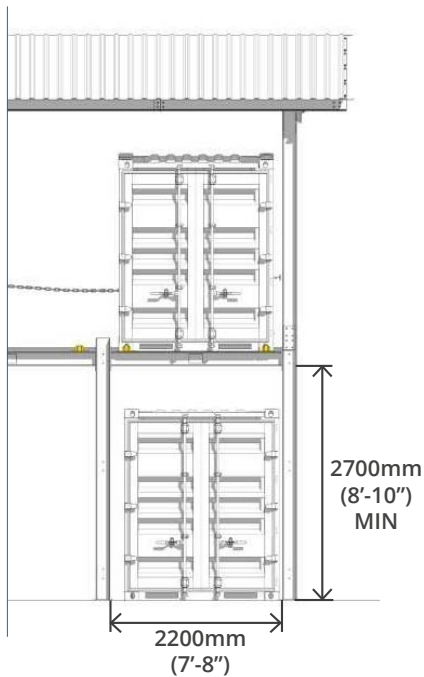
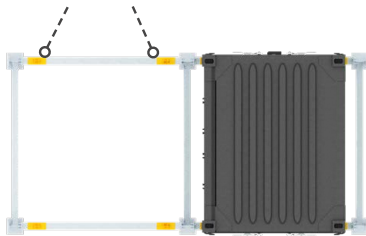

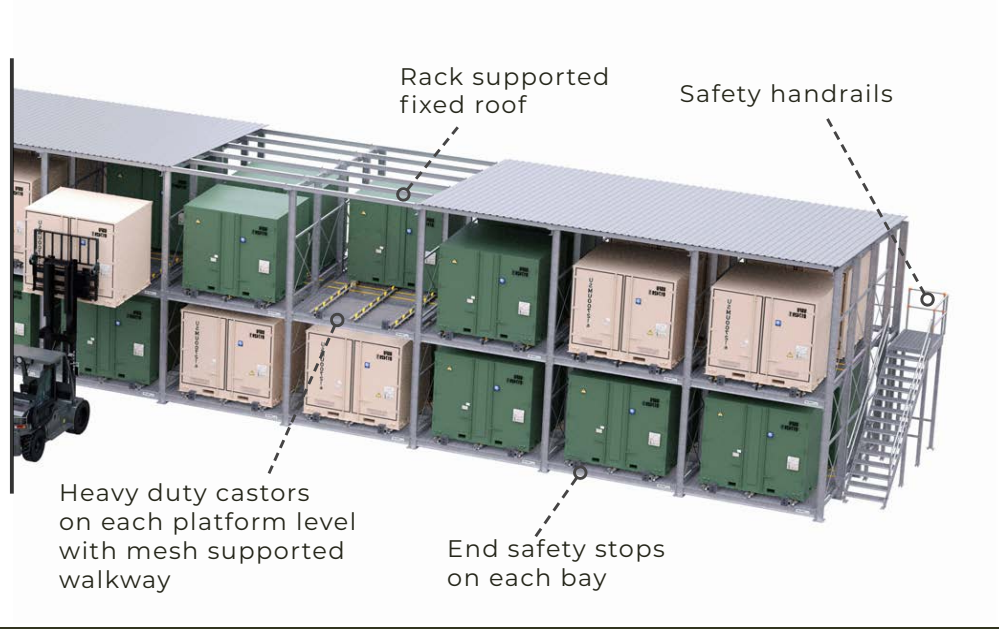

PUSH BACK

MILITARY CARGO RACK
Flexible Storage Solutions For Cargo

PUSH BACK

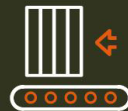

STACKABLE



SPACE SAVING



DURABLE



FORKLIFT



TOP VIEW

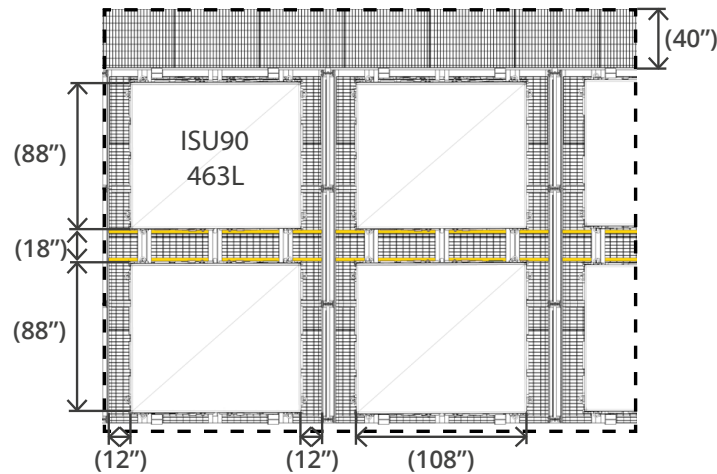

BAN-AIR PUSH BACK MILITARY RACK is custom designed for dense storage where space is constrained, **specifically to store both 463L ('ALOC') and ISU90 containers.**

Heavy duty castors on each platform level allow the push back of ISU90/463L positions





FRONT VIEW

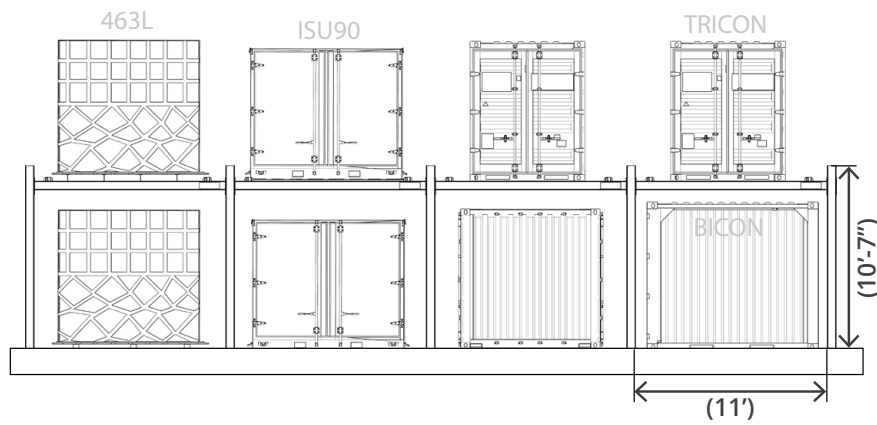

UNIVERSAL 
MILITARY CARGO RACK
 Flexible Storage Solutions For Cargo

ADAPTABLE

STACKABLE

SPACE SAVING

DURABLE

FORKLIFT



Custom steel lugs engage with the BICONS four corner castings.

Five support runners back-to-back support ISU90 / TRICON loads.

BAN-AIR UNIVERSAL RACK is perfect when a variety of cargo sizes are required for storage.

Each position has capacity to store **463L, ISU, Bicon, or Tricon.**





MANUFACTURER

WWW.BAN-AIR.COM

SALES@BAN-AIR.COM

+44 121 401 1122 (EUROPE)

+1 919 753 8429 (USA)